

2019

Protect the environment - tile coating - shops and stairs against salt



Saltnex

Saltnex ApS - Nyholmsvej 7, DK 8930 Randers NØ - CVR: 37629782 - Tlf: +4521267639
Mail: hc@saltnex.dk - lene@saltnex.dk - www.saltnex.dk



A series of salt and liquidspreaders for small tractors and tool carriers. The series comes with manual operation or CPU computer control with remote control, which regulates according to the entered quantity and driving speed with start and stop. Spreading width for saltspreader 1 to 6 m. and for the liquid spreader 1 to 5m.



Saltnex develops and sells machines for winter maintenance and cleaning of sidewalks, cycle paths, pedestrian zones etc. Saltnex ApS is a part of Randers Maskinfabrik group. Hans Curt Nexgaard is projectmanager for Saltnex and he brings with him a wealth of know-how from years of experience in the field of development and marketing of the machines.

Saltnex



Liquidspreader for all types of models from 200L to 1750L



Saltnex



2

Focus on the environment by winter road maintenance



Saltnex

Focus on the environment by winter road maintenance



model 7.2 200 L

Saltnex

Focus on the environment by winter road maintenance

400 L for Hako600 and HAKO1250 - 600L for Hako1600



Saltnex

Focus on artificial turf



model 7.3 - 700L Turf

Saltnex



Focus on the environment by winter road maintenance

2



Width 71 cm - Height 60 cm

50 L Trolley with electric pump and charger.
Spreading width 80 cm.
5 m. hose with hand lance.
Adjustable fluid quantity, manometer for checking amount of liquid.
Big pneumatic tires and adjustable handles.
Side nozzles with tap, spreading width 2m.
Battery capacity for 6 x 50L.



Also with drawbar

200L. with CPU-control for tool carriers.
e.g. Kärcher Mic 34 and Egholm 2150 - 2250

Pump 65L /min. Spreading width 1 to 3m. (Option: Other pumps and spreading width)

Model 7.2

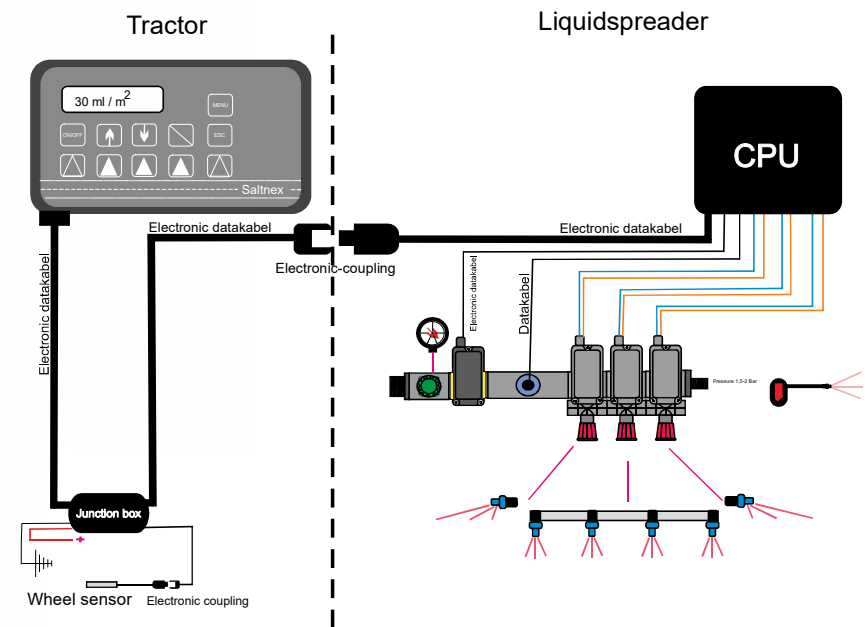

Saltnex

350L and 500L. with CPU control for tool carriers
e.g. Kärcher Mic 42 - 50 and Vitra

Pump 65L /min. Spreading width 1 to 3m. (Option: Other spreading width)

Model 7.2

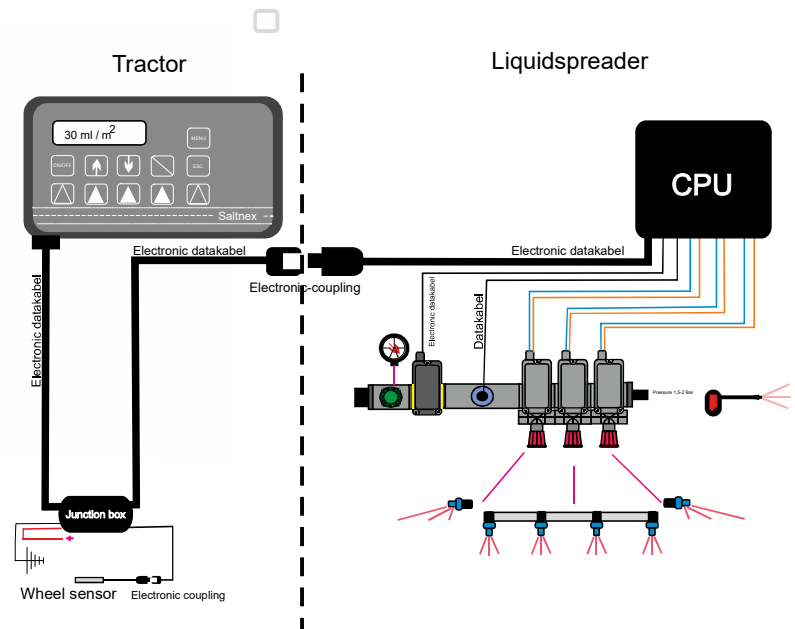

Saltnex

350L. short model with CPU control for tool carriers.
e.g. Timan tool trac 245 and timan 3400

Pump 65L /min. Spreading width 1 to 3m. (Option: Other Spreading widths)

Model 7.2

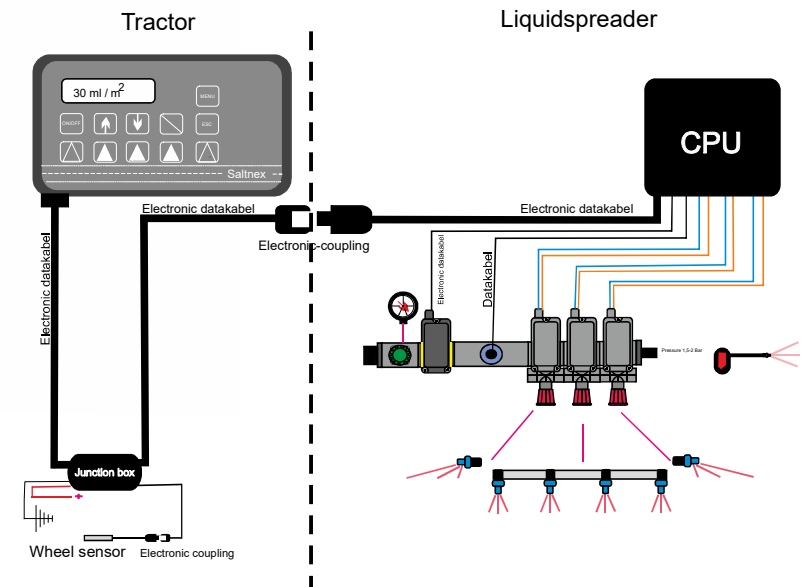

Saltnex

400L & 600L with CPU control for Hako models 600 - 1250 - 1600

200L space-divided tankspumps 65L /min. Spreading width 1 to 3m. (Option: Other spreading widths)

Model 7.4

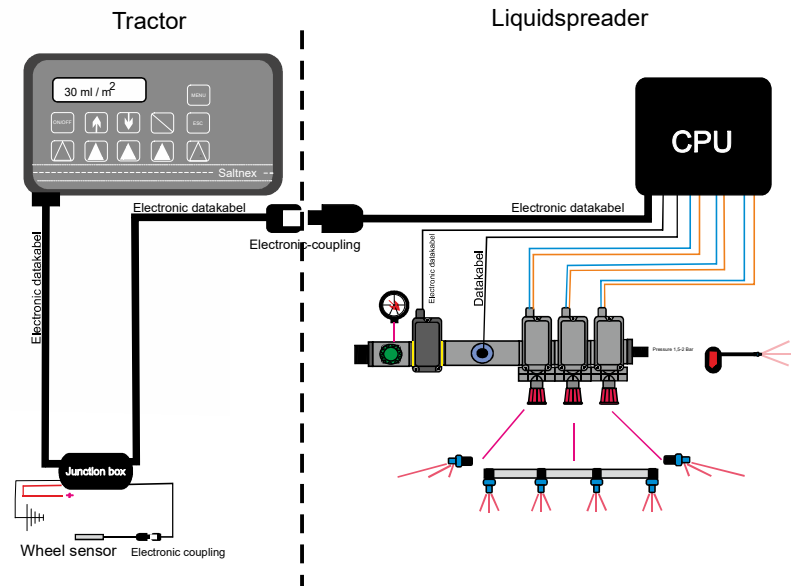

Saltnex

350L & 500L Lift model with CPU control for small tractors

Pump 65L /min. Spreading width 1 to 3m. (Option: Other spreading widths - spraysystem)

Model 7.1

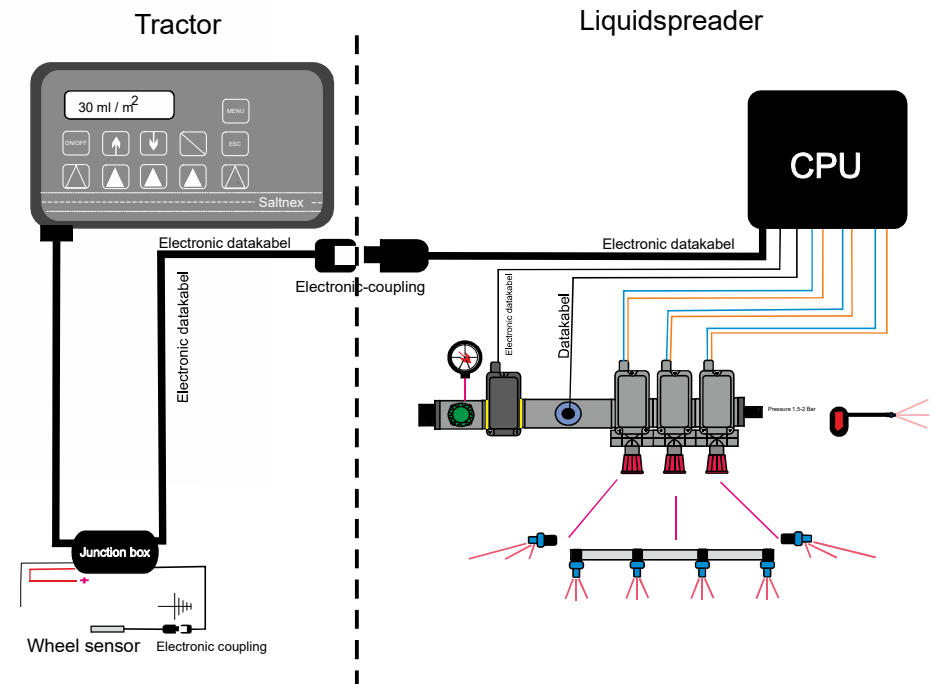

Saltnex

800L. lift model with spreading width 1m x 1,3m x 1m

Option: Other spreading width

Model 7.1

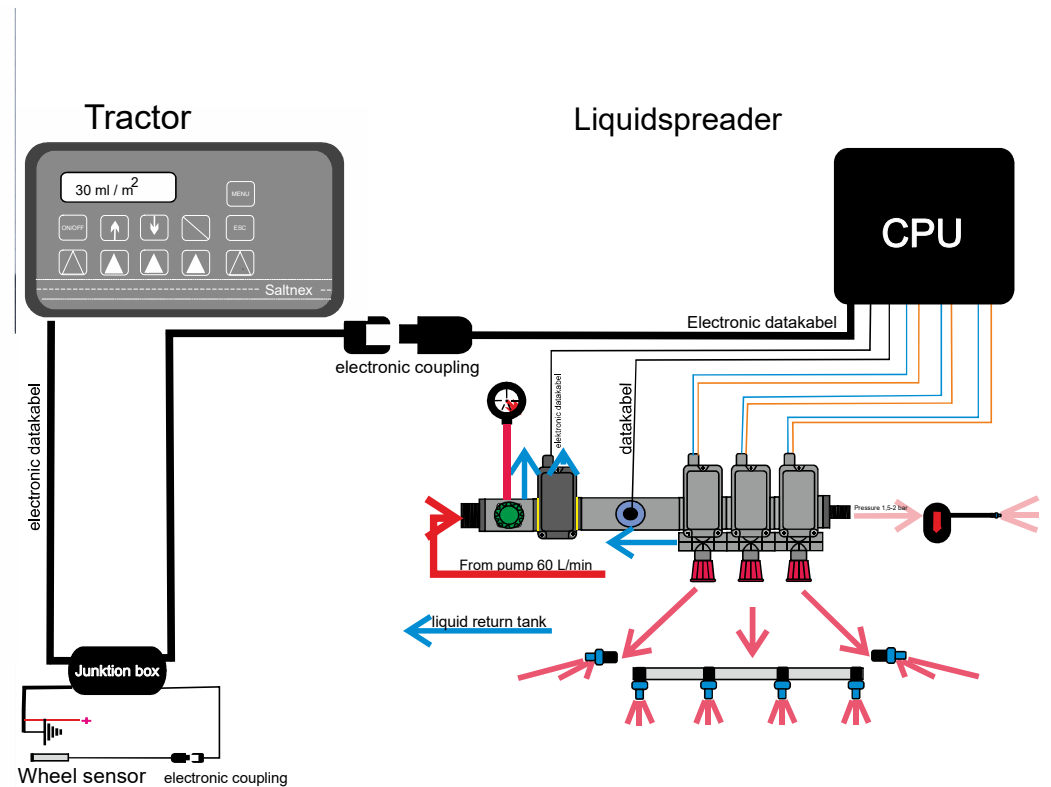

Saltnex

1050L & 1400L trailer with hydraulic or brakes

Tanks: 350L divided in two rooms. Pump 65L /min. Spreading width 1 to 3m. (Option: Other spreading width)

Model 7.3

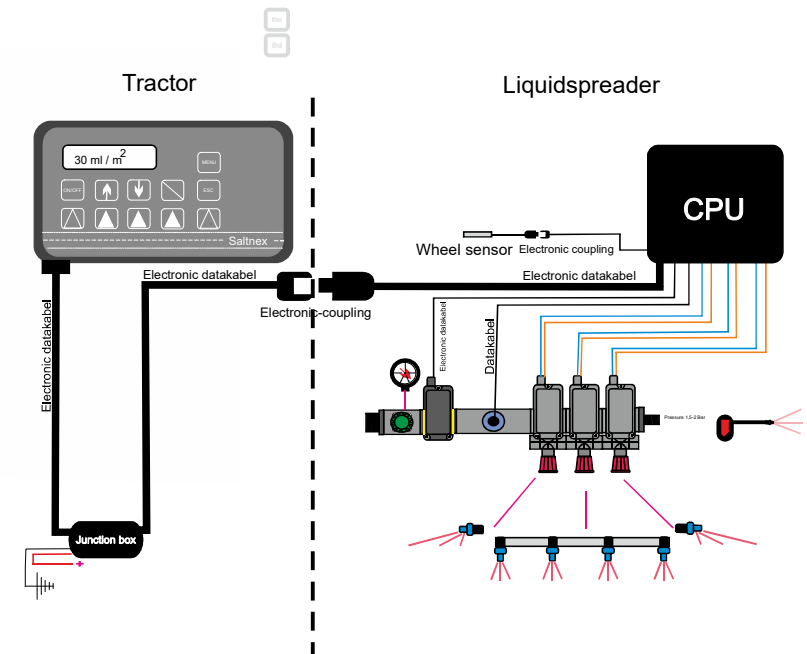

Saltnex

700 - 1050 - 1400 - 1750L. with road-speed related CPU control

Tanks: 350L divided in two rooms. Pump 65L/min. Spreadingwidth 1 to 3 m (Option: other spreadingwidths)

Model 7.4

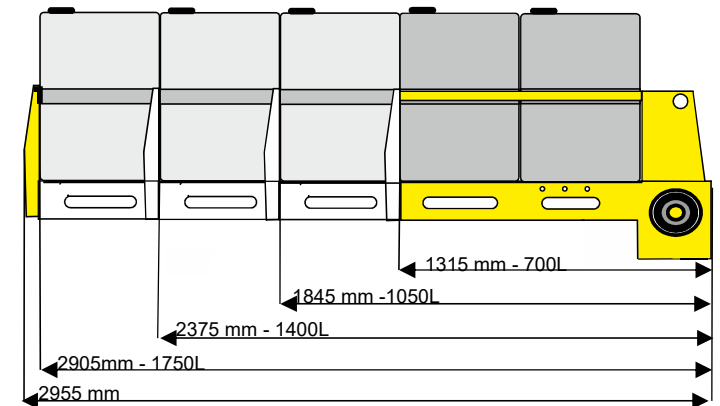
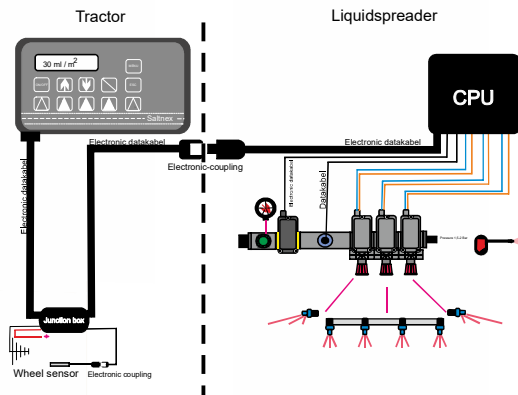

700L. with 52 L electronic pump with tubular cells battery
+ road-speed related CPU control.

Tanks: 350L divided in two rooms. Pump 52/min. Spreading width 1,30 to 3,30m

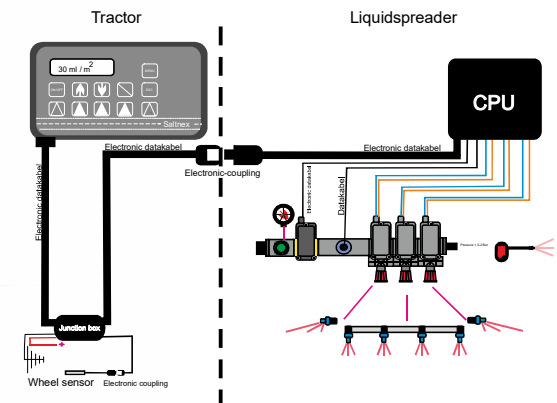

Saltnex

700L. trailer for artificial turf- 3 sections 5 m. - ground pressure 0,49kg/cm²
brine/CMA for artificial turf in winter - fertilizer for grass pitches in summer.

model 7.3 turf



Road-speed related steering -
all is regulated by remote control.

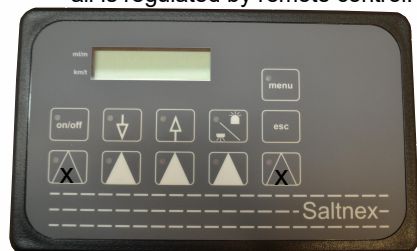

x- up/down side bars



Saltnex

It is so easy

Road-speed control.
The daily service is very simple.
Press the arrow keys and the
quantity is adjusted up/down.
The display shows: ml/m²

Press the side nozzle or bars.

Very easy



Saltnex

Mix it yourself 1000L. mixing tank on pallet

Model 7.9



Mixing plant consisting of:
 1000L. pallet with lid.
 2 pcs. pumps, mixing capacity
 480L/min.
 Filling capacity 150L/min.
 230V: with liquid scale and
 reframeter for fluid control.

Also available as picture with 1000L
 storage tanks with pumps.



Filling pump for CMA - Viaform etc.



Stationary filling pump with 4 m.
 hose and coupling.
 230 V. 160 l/min.
 with connection to pallet tank.

Electronic liter counter.

Mix table 20% Brine, Density 1,115

| Total Quantity | | | |
|----------------|--|----------|----------|
| Brine L. | | Water L. | Salt Kg. |
| 100 | | 92 | 23 |
| 200 | | 184 | 46 |
| 300 | | 276 | 69 |
| 400 | | 368 | 92 |
| 500 | | 460 | 115 |
| 600 | | 553 | 138 |
| 700 | | 645 | 161 |
| 800 | | 736 | 184 |
| 900 | | 828 | 207 |
| 1000 | | 920 | 230 |

Saltnex

10 points to consider

Protect shops and offices against salt.

Protect sensitive coatings and underlays against salt.

Protect trees, shrubs and other plants against salt.

Protect the bikes against punctures.

Protect the paws of the pets against salt.

Protect yourself from dissatisfied citizens complaining about the salt mess

Save money on consumption of salt.

Save time, there is no calibration

Save money with less equipment maintenance.

Save money with less consequential damage on coatings.

The logo for Saltnex is centered within a dark grey horizontal bar that has a dashed white border. The word "Saltnex" is written in a white, sans-serif font.

Saltnex ApS - Nyholmsvej 7, DK 8930 Randers NØ - CVR: 37629782 - Tlf: +4521267639
Mail: hc@saltnex.dk - lene@saltnex.dk - www.saltnex.dk